

4

3

2

1

B

B

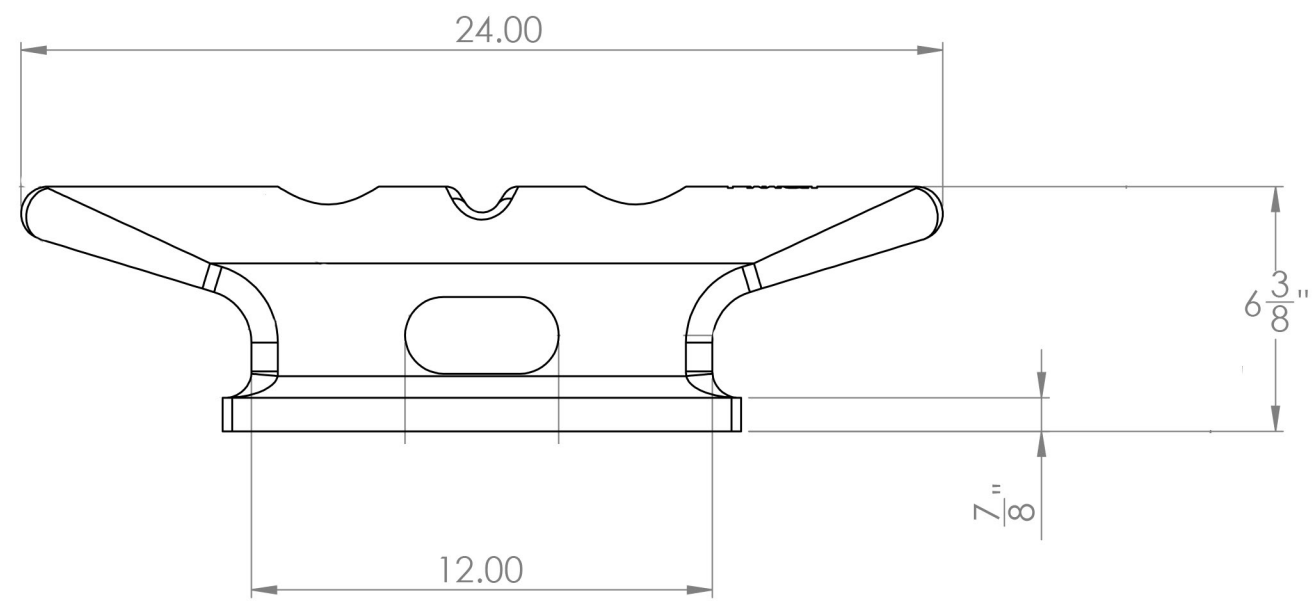
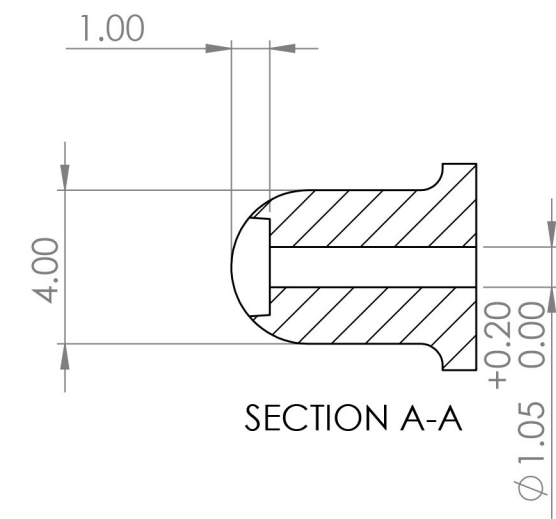
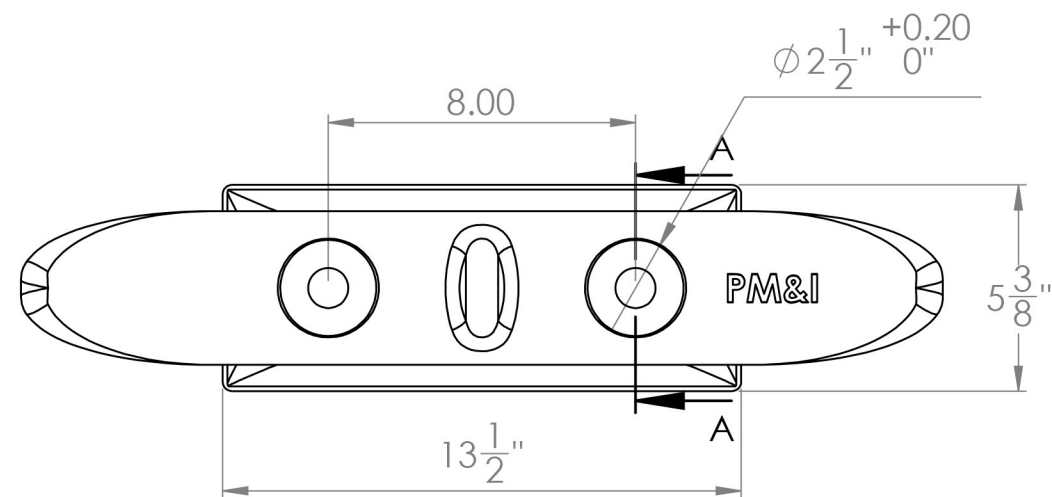

A

A

Note 1: Product designed for 1 inch heavy hex head bolts using 1 5/8 heavy hex head socket

PROPRIETARY AND CONFIDENTIAL
 This document is confidential and contains trade secrets of Pacific Marine & Industrial (PM&I). It is NOT to be copied in whole or in part or distributed without express written permission from PM&I.

UNLESS OTHERWISE SPECIFIED:		NAME	DATE	Pacific Marine & Industrial 555 South 12th Street Richmond, CA, USA 94804		
DIMENSIONS ARE IN INCHES TOLERANCES: FRACTIONAL ± 1/16" ANGULAR: MACH ± BEND ± TWO PLACE DECIMAL ±0.01 THREE PLACE DECIMAL ±0.005		DRAWN				TITLE: <h2 style="text-align: center;">PC2-24 Cleat</h2>
INTERPRET GEOMETRIC TOLERANCING PER:		CHECKED		SIZE	DWG. NO.	
MATERIAL		ENG APPR.				
FINISH		MFG APPR.			SCALE: 1:5	WEIGHT:
DO NOT SCALE DRAWING		Q.A.				

4

3

2

1