

# SPINNER II<sup>®</sup>

OIL CLEANING CENTRIFUGE

**Model 25**

0.9 gpm at 60 psig  
250 cc Dirt Capacity

Installation Instructions

Parts List

Service Instructions



[WWW.PACIFICMARINE.NET](http://WWW.PACIFICMARINE.NET)

Bulletin 71951

**Oil Supply to Centrifuge**

**Oil supply** should, in general, be taken from the highest pressure, hottest source available immediately downstream of the lube pump. A 3/8" pipe (or #6 hose) supply line should be used. The unit's supply port is a #6 female SAE O-ring design (9/16-18 straight thread). Preferred pressure is 60 to 80 psig but the Spinner II centrifuge will operate efficiently at 35 to 90 psig. The idle Cut-Out Valve (COV) allows oil to enter the unit only when supply pressure exceeds 20 psi.

**Clean Oil Return to Sump**

**Gravity Drain.** The Spinner II centrifuge must be close-coupled to the sump with an unrestricted 1" ID (or #20 hose) drain returning above the normal sump oil level. The drain line must be sloped downward from the centrifuge outlet and be free of sharp bends or traps. On many engines, an access plate into the gear train or crankcase can be modified to provide a suitable drain opening as well as sturdy mechanical support. Be sure the sump side of the drain opening is clear and that the drain oil does not impinge on moving parts of the engine.

**Mechanical Considerations**

**Spinner II centrifuges** are high-speed devices and should be securely mounted to prevent excessive vibration. Operation up to 10 or 15 degrees from vertical is permitted. Further installation guidelines are provided in Spinner II diagram A1-5154.

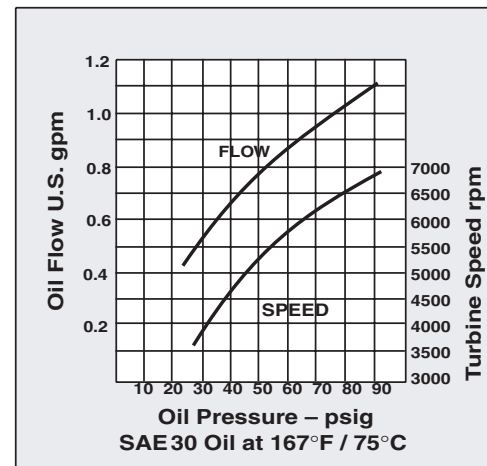
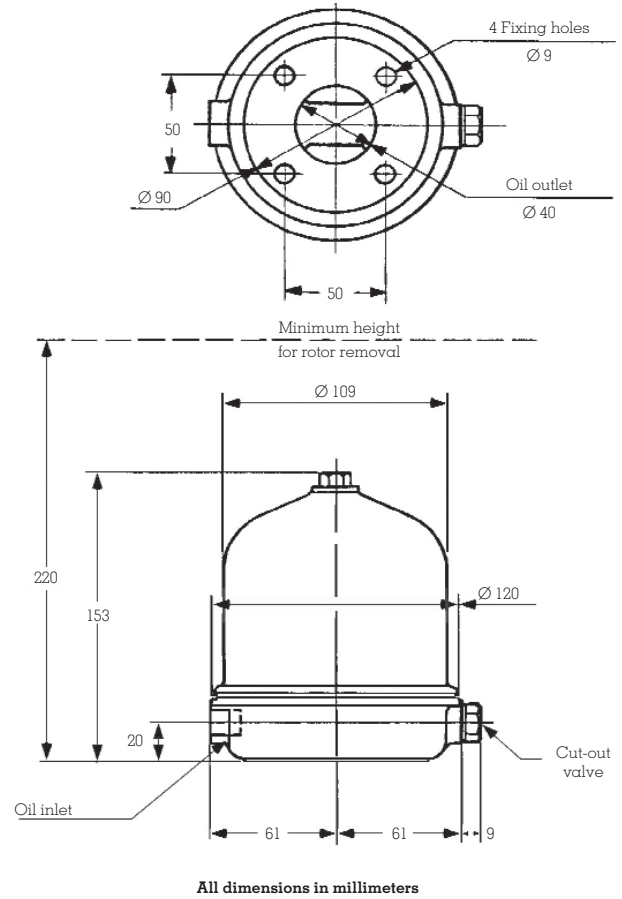

# Model 25 Parts List

**Description** **Part number**

Only items shown with part numbers are available.

**Bold denotes assembly**

**Centrifuge, Spinner II/Model 25 with COV (Cut-Out Valve).... 71957**

**Cover assembly** ..... **71080**

Nut-cover ..... 71081

■ Seal-cover nut ..... 71082

Ring, retaining-cover nut ..... 71083

**Centrifuge turbine assembly** ..... **71085**

Nut-centrifuge bowl ..... 71086

Bowl-centrifuge ..... 71087

● Seal-centrifuge turbine, nitrile ..... 71089

Standtube-centrifuge ..... 71088

● Turbine body ..... 71952

Nozzle-turbine (2 required) ..... part of 71085

**Base assembly with spindle** ..... **71979**

● Seal-base to cover (nitrile) ..... 71084

■ **Kit cut-out valve** ..... **71950**

Gasket-base ..... 71091

**Service Cycle** ● Whenever bowl is cleaned or replaced.

■ At unit rebuild or when required.

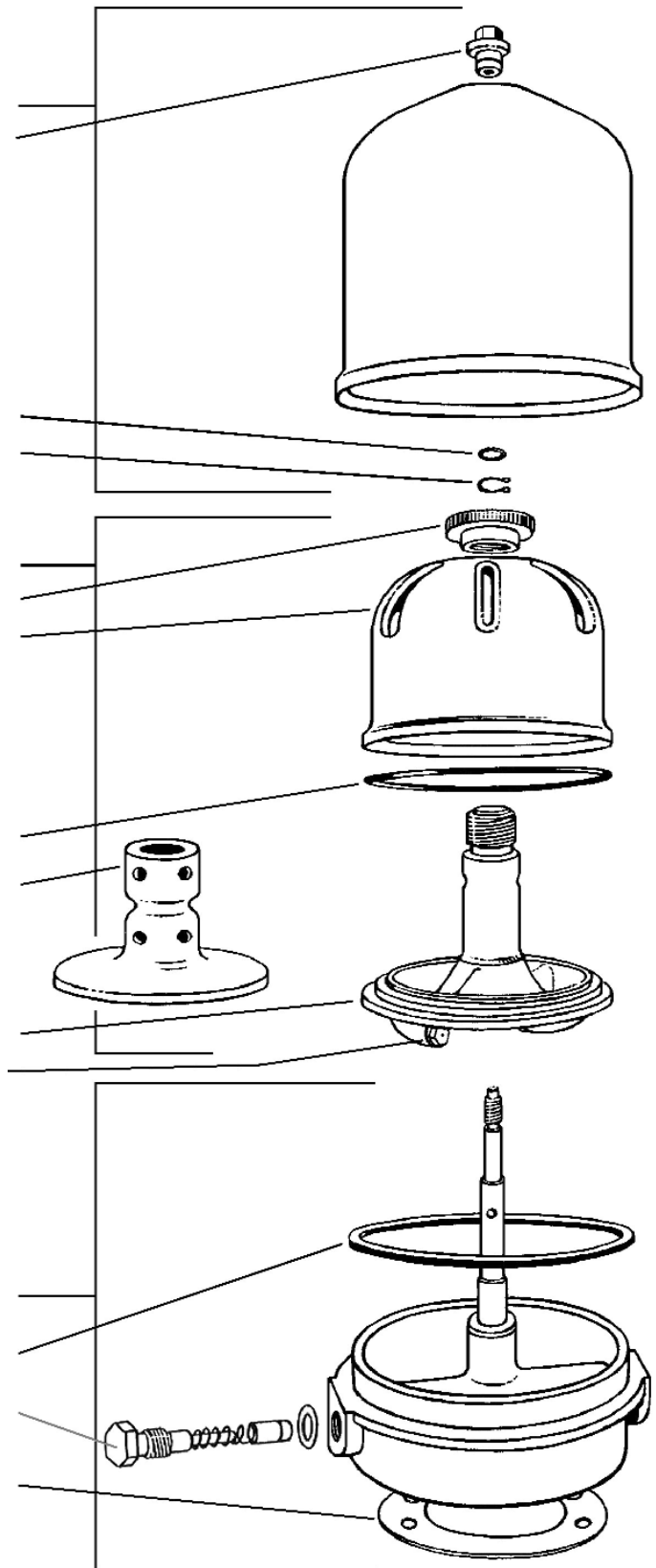

1. Shut off oil supply (or stop engine) and allow centrifuge turbine assembly to come to a complete stop.
2. Unscrew cover nut and remove cover assembly.
3. Partially withdraw centrifuge turbine assembly from the housing and allow oil to drain from nozzles before removing completely. Hold the assembly in one hand and remove bowl nut. Carefully separate centrifuge bowl from turbine. Remove stand tube.
4. Carefully remove sludge from centrifuge bowl using a wooden spatula or other non-damaging tool.
5. Wipe out bowl with solvent and wash stand tube and other parts.
6. Clean turbine and examine top and bottom bearings for excessive wear. Check turbine nozzles to ensure free passage of oil. Replace centrifuge bowl seal.
7. Seat stand tube in turbine, replace bowl and reassemble centrifuge, tightening the bowl nut securely by hand and making sure that the bowl seal is uniformly seated all around.
8. Examine spindle journals for damage or excessive wear. Replace base assembly if journals are damaged. Spindle is pressed into base and aligned at the factory and cannot be properly serviced in the field.
9. Replace centrifuge turbine assembly on spindle, being careful of bushings. Be sure it rotates freely.
10. Clean and inspect cover, paying special attention to cover-nut assembly. The seal should be replaced if it shows signs of leaking.
11. Examine the base-to-cover seal and replace if damaged.
12. Replace cover assembly and tighten cover nut securely to 8 ft-lbs maximum. Make sure that cover seats on base assembly evenly all around so that cover seal is properly compressed. Check all centrifuge mounting bolts for proper tightness.
13. Open oil supply to centrifuge. With engine running, check all connections and joints for leaks. Repeat assembly if vibration is excessive.

**[WWW.PACIFICMARINE.NET](http://WWW.PACIFICMARINE.NET)**