

DIMENSIONAL/PERFORMANCE DATA

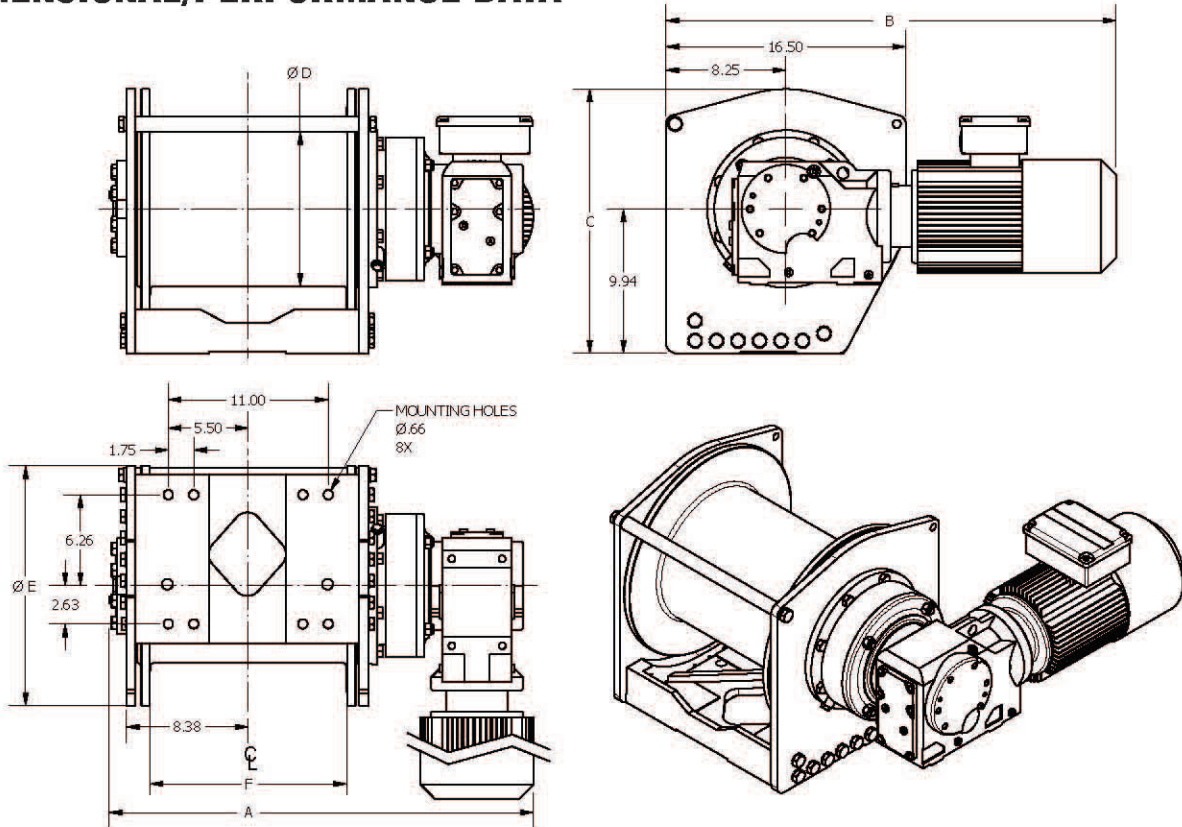

Model	Motor HP	Typical Weight	Calculated Performance (5/8" wire rope)					
			First Layer		Mean Drum		Full Drum	
			LBS	FPM	LBS	FPM	LBS	FPM
HL6000 ¹	3.0	482 lbs	6,000	15	5,200	18	4,450	21
HL9000 ¹	3.0	482 lbs	9,000	10	7,700	12	6,600	14
HL12000 ¹	3.0	500 lbs	12,000	7	10,200	9	8,700	10
HL12000 ¹	5.0	500 lbs	12,000	13	9,600	16	8,200	18
HL12000 ²	7.5	579 lbs	12,000	17	9,600	24	7,900	29
HL15000 ²	3.0	520 lbs	15,000	6	10,400	8	8,600	10
HL15000 ²	5.0	528 lbs	15,000	11	11,400	14	9,400	17
HL15000 ²	7.5	579 lbs	15,000	15	11,000	21	9,100	25

¹ -02 drum performance ² -04 and -05 drum performance

Performance based on 230/460 3Ø 60 Hz input power; other voltages available

Drum Size	Dimensions						Wire Rope Capacity, Feet		
	A	B	C	D	E	F	1/2"	9/16"	5/8"
-02	28.8"	31.8"	17.9"	9.8"	16.4"	13.8"	547	399	368
-04	29.5"	39.3"	22.0"	10.6"	20.0"	13.5"	957	756	589
-05	30.6"	35.6"	18.0"	10.6"	16.5"	13.8"	470	427	300

Typical dimensions shown; gearmotors can be rotated in 90° increments